

AIRBORN INC.
PRODUCT TECHNICAL BULLETIN #44

INSTALLATION OF BAND-IT TIE-DEX BANDS

PURPOSE

The purpose of this technical bulletin is to provide recommendations for successful installation of Band-It Tie-Dex bands to ensure permanent EMI/ RFI cable shield terminations on AirBorn connector backshell configurations.

SCOPE

These recommended work instructions apply to using the Band-It Tie-Dex II tool to install the Band-It Tie-Dex Band.

SPECIAL TOOLING REQUIRED

AirBorn recommends the use of the following tools and associated parts.

Band-It Tie-Dex II Tool; #A30199; CDG10027

Band-It Tie Dex Band; 1/8" Band; CDG10026

Tool Blade; #A46787

Knife; #A48087

GENERAL INFORMATION & RECOMMENDATIONS

- Prior to use, it is recommended to inspect the Band-It Tie-Dex tool for blade condition and damage to the tool around the blade cut off area. Replace the cut off blade and/or tool as required.
- Band tension is sufficient when the band securely holds the shield/braid to the hood. Hold the hood and try to rotate the band and shield. If no movement is observed the band is installed correctly. The tool calibration key is inserted into the back of the tool and rotated clockwise to increase the tension as well as counter-clockwise to decrease tension. One turn = approximately 7 lbs.
- AirBorn recommends positioning the locking lip of the Band-It Tie Dex Band along the longer portion of the backshell exit to ensure a more uniform band and shield/braid compression. See Figures 1 & 2.



Figure 1.



Figure 2.

- Following band and shield/braid compression at the backshell exit; AirBorn recommends removing any additional shield/braid outside of the compressed location on the backshell. This minimizeS sharp edges when using shrink tubing as additional protection. See Figure 3.



Figure 3.

PROCEDURE/PROCESS

The following procedures, processes, and figures were obtained from the following reference. Please refer to the website below for further instructions as needed.

1]BAND-IT. "Operation Instructions for A301/A401 Tie-Dex II Tool." 2005. 30 Sept 2005 <[http:// www.band-it-idex.com/products_tools.asp](http://www.band-it-idex.com/products_tools.asp)>.

STEP 0: To free handles, squeeze handles together and move holding clips to center.

STEP 1: Create double wrapped clamp by feeding end of band through narrow slot on buckle twice. Pull on clamp tail by hand to reduce loop diameter for faster installation on small objects. Squeeze gripper release lever and insert band as far as possible. Tie-Dex Bands must always be double-wrapped.

STEP 2: Repeatedly squeeze pull-up handle until handle locks against tool body.

STEP 3. Squeeze cut-off handle and remove excess band.

NOTE 1: When tensioning band, always let pull-up handle return to its original position. If handle is stuck in between strokes, push back down for full stroke.

NOTE 2: To loosen or remove clamp before locking and cut-off, squeeze gripper release lever and pull band out.

NOTE 3: To loosen or remove clap after pull-up handle locks against tool body, squeeze handles together and push tension release lever forward. Use same lever to release tension when calibrating tool.

NOTE 4: Please refer to tooling manufacture for removal and replacement of any damaged parts.

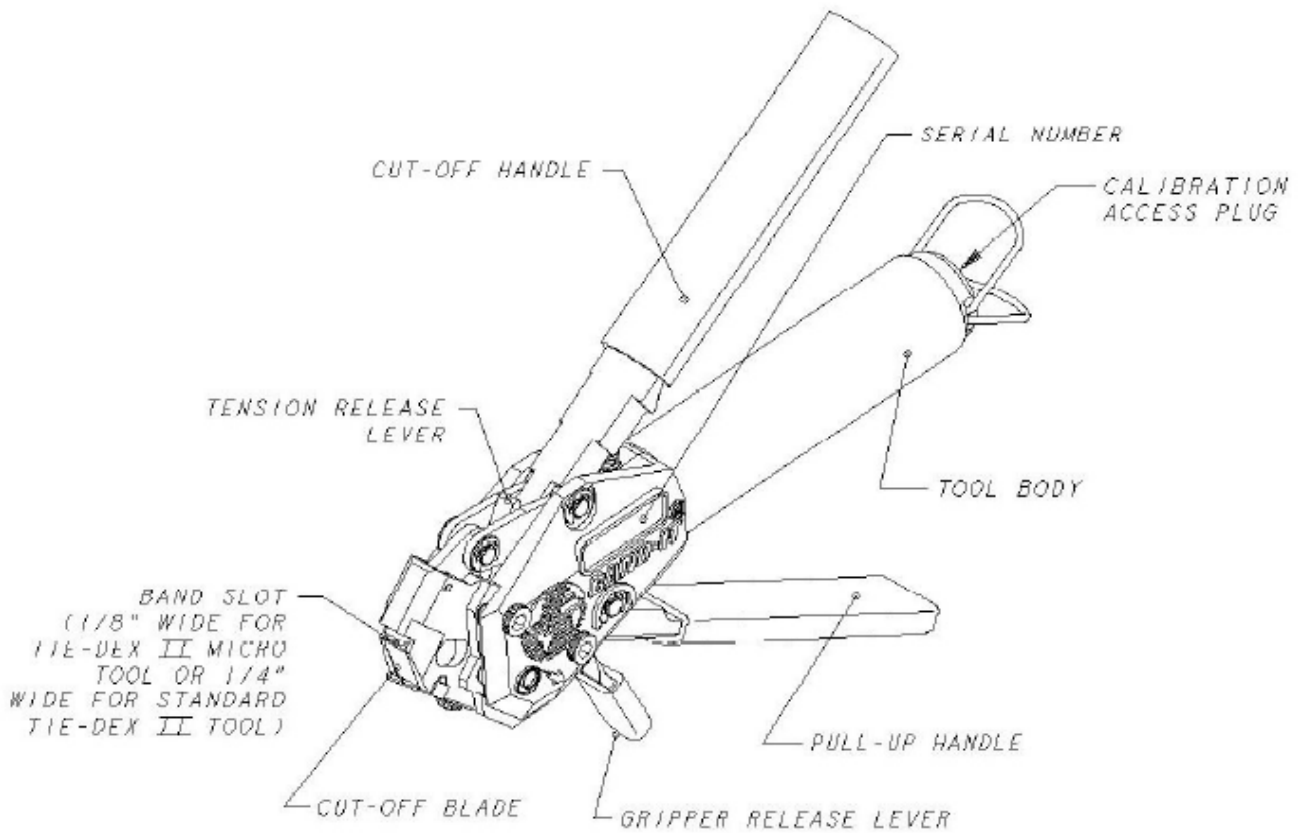

Replacement Parts						
Tool Model	Cutter Blade Kit	Blade	Knife (See sheet 3)	Mounting Pin	Factory calibrated tension	Tension range
A40199 1/4"	A40699	A40687	New – A67787 Old – A40788	M06487	150 ±5 LBS	100-180 LBS
A30199 1/8"	A46799	A46787	A40887	M06987	80 ±5 LBS	50-100 LBS

Figure 4.

1. Create double wrapped clamp by feeding end of band through narrow slot on buckle twice. Pull on clamp tail by hand to reduce loop diameter for faster installation on small objects. Squeeze gripper release lever and insert band as far as possible.

CAUTION: Never use band as a single wrapped clamp!



2. Repeatedly squeeze pull-up handle until handle locks against tool body. Always allow pull-up handle to return to its original position after each stroke. Correct tension is reached when pull-up handle locks against tool body.

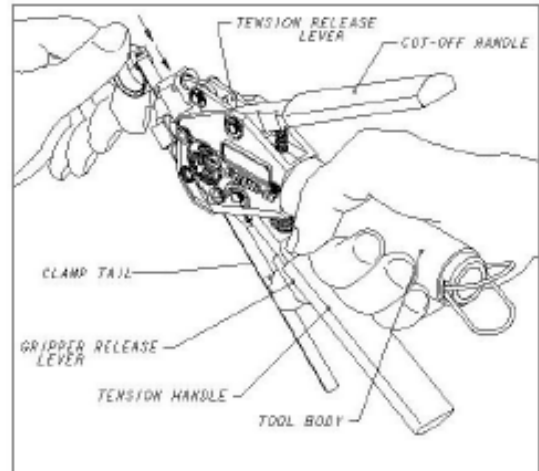
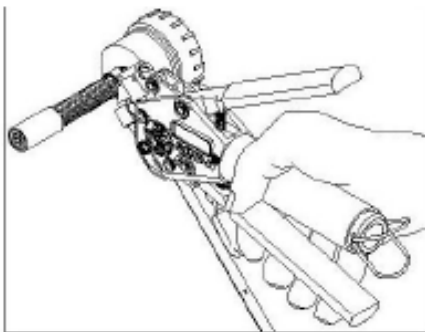

3. Squeeze cut-off handle once against tool body to form lock and trim excess band. Tension handle will release. Remove band from tool.

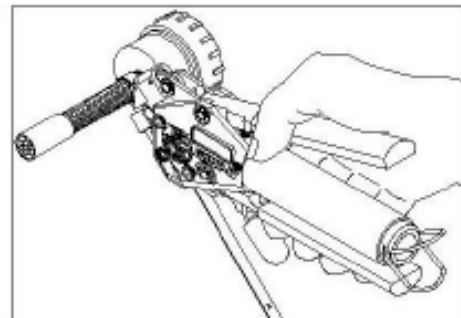

4. To loosen or remove clamp before locking and cut-off, squeeze gripper release lever on tool and pull band out.
5. To loosen or remove clamp after pull-up handle locks against tool body, squeeze pull-up handle and push tension release lever forward. Let tension handle return to its original position, then use gripper release lever and pull band out.
6. Completed clamp may be covered with shrink wrap or tape for protection.

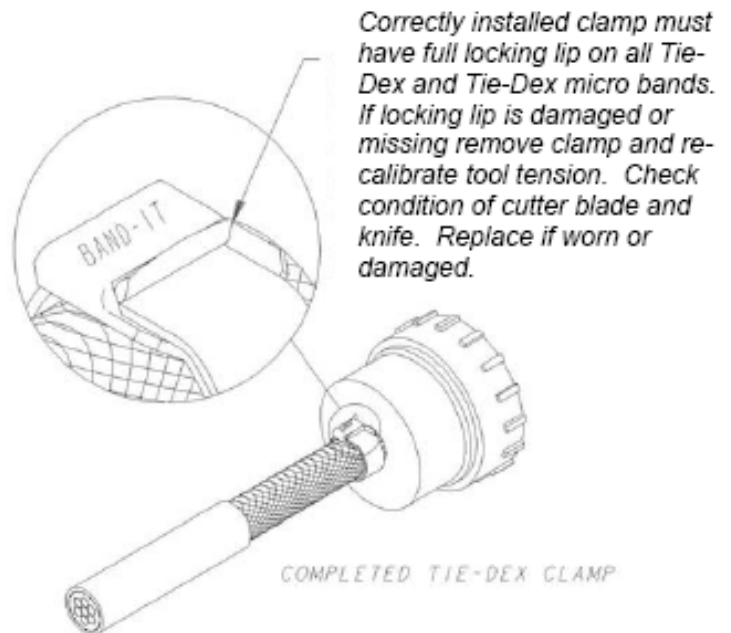

Figure 5.