



Rugged Vertical SMT Turning Hardware

1 thru 10 High Speed Modules
0 thru 50 Signal Contacts

MLHS

MLHS-03L2-800-475-2810

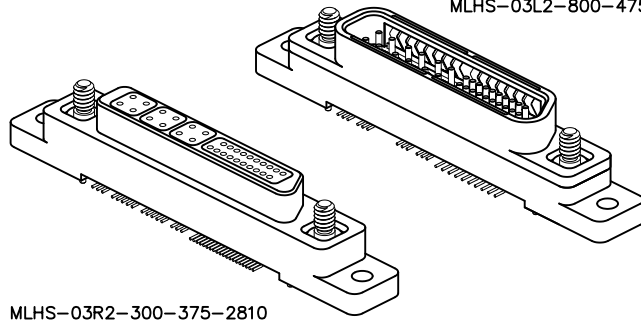

MLHS-03R2-300-375-2810

SINGLE-SIDED LEADS SHOWN

STAGGERED LEADS SHOWN

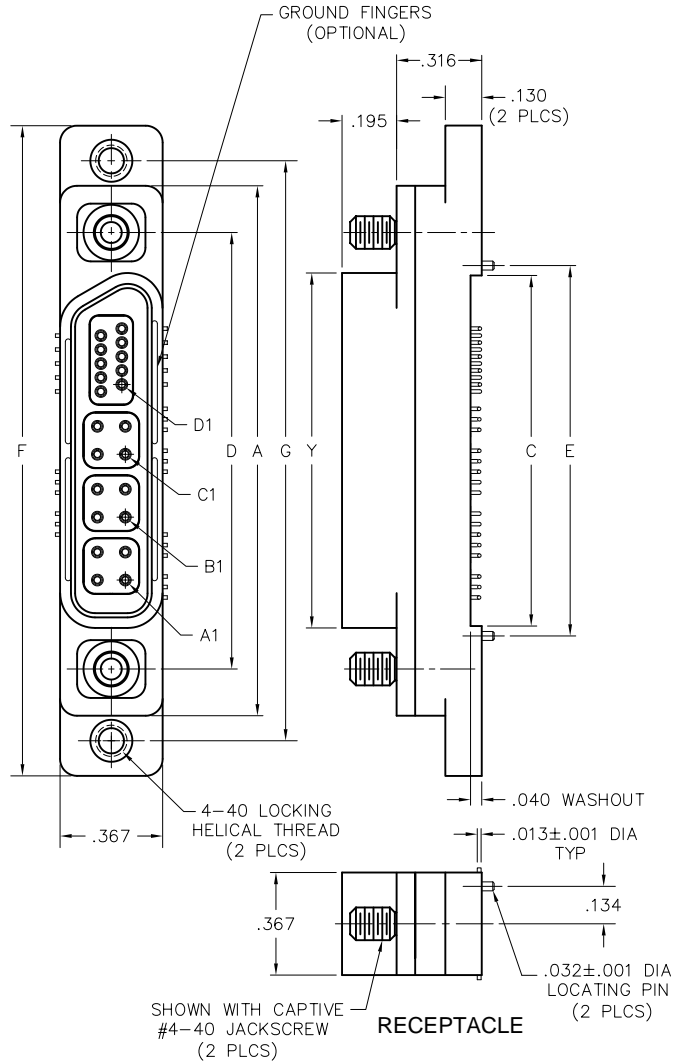
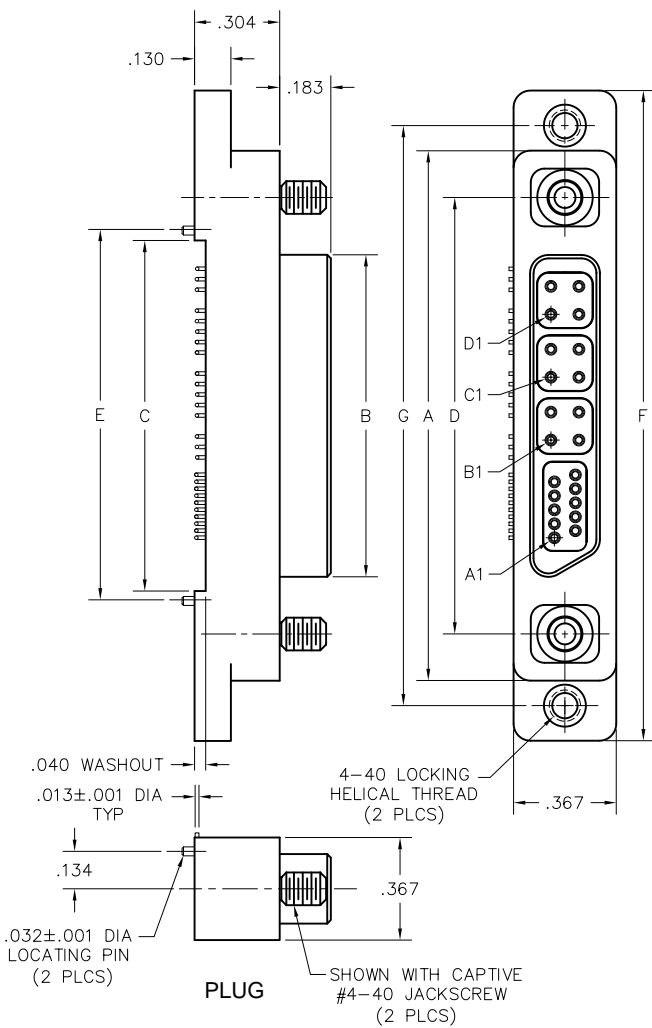

INTERFACE DIMENSIONS

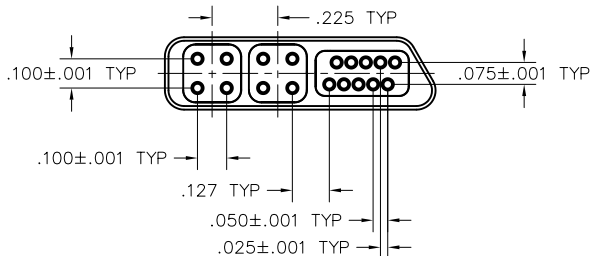

DIMENSIONS	
A	BODY LENGTH (W/O FEET) FOR V-SMT TURNING HARDWARE PER TABLE CALCULATION (SEE PAGE 6)
B	"A" MINUS 0.744
C	"A" MINUS 0.640
D	"A" MINUS 0.320
E	"A" MINUS 0.570
F	"A" PLUS 0.430
G	"F" MINUS 0.250
Y	"A" MINUS 0.624

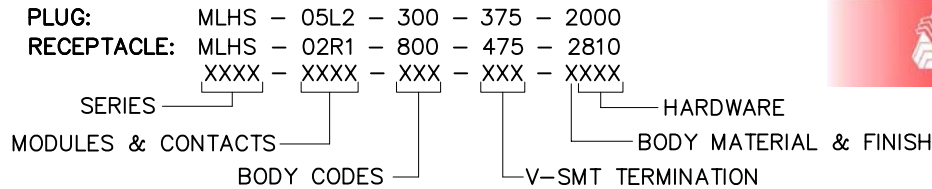

PLUG

SERIES

MLHS HIGH SPEED Rugged Metal Vertical SMT
(MLHS mates with MMHS, MJHS receptacles)

HIGH SPEED MODULES

- 01 1 High Speed Module
- 02 2 High Speed Modules
- 03 3 High Speed Modules
- 04 4 High Speed Modules
- 05 5 High Speed Modules (Max Signal Count 40)
- 06 6 High Speed Modules (Max Signal Count 30)
- 07 7 High Speed Modules (Max Signal Count 20)
- 08 8 High Speed Modules (Max Signal Count 10)
- 09 9 High Speed Modules (Max Signal Count 10)
- 0A 10 High Speed Modules (No Signals)

SIGNAL CONTACTS*

- L0 Left Side Key - No Signal Contacts
- L1 Left Side Key - 10 Signal Contacts
- L2 Left Side Key - 20 Signal Contacts
- L3 Left Side Key - 30 Signal Contacts
- L4 Left Side Key - 40 Signal Contacts
- L5 Left Side Key - 50 Signal Contacts
- R0 Right Side Key - No Signal Contacts
- R1 Right Side Key - 10 Signal Contacts
- R2 Right Side Key - 20 Signal Contacts
- R3 Right Side Key - 30 Signal Contacts
- R4 Right Side Key - 40 Signal Contacts
- R5 Right Side Key - 50 Signal Contacts

BODY STYLE

- 300 Plug, Vertical SMT w/ Mounting Ears

CONTACT TERMINATION

- 37 Pin, Vertical SMT, Staggered Leads - All
- 57 Pin, Vertical SMT, Staggered Leads - High Speed Single-Sided Leads - Signals
- 77 Pin, Vertical SMT, Single-Sided Leads - High Speed Staggered Leads - Signals
- A7 Pin, Vertical SMT, Single-Sided Leads - All

TERMINATION PLATING

- 5 50 micro" Gold Contact, Sn/Pb Alloy Termination
- 7 50 micro" Gold Contact, SAC305 Plated Termination

BODY PLATING (LCP INSULATORS)

- 2 Electroless Nickel Plated Aluminum Shell
- 3 Electrodeposited Cadmium Plated Aluminum Shell
- 6 Gold Plated Aluminum Shell

HARDWARE

- 000 No Hardware
- 810 Two Turning Jackscrews, Allen Head, Captivated **
- JXX Keying Jackscrew Hardware, See Options ***

RECEPTACLE

SERIES

MLHS HIGH SPEED Rugged Metal Vertical SMT
(MLHS mates with MMHS, MJHS plugs)

HIGH SPEED MODULES

- 01 1 High Speed Module
- 02 2 High Speed Modules
- 03 3 High Speed Modules
- 04 4 High Speed Modules
- 05 5 High Speed Modules (Max Signal Count 40)
- 06 6 High Speed Modules (Max Signal Count 30)
- 07 7 High Speed Modules (Max Signal Count 20)
- 08 8 High Speed Modules (Max Signal Count 10)
- 09 9 High Speed Modules (Max Signal Count 10)
- 0A 10 High Speed Modules (No Signals)

SIGNAL CONTACTS*

- L0 Left Side Key - No Signal Contacts
- L1 Left Side Key - 10 Signal Contacts
- L2 Left Side Key - 20 Signal Contacts
- L3 Left Side Key - 30 Signal Contacts
- L4 Left Side Key - 40 Signal Contacts
- L5 Left Side Key - 50 Signal Contacts
- R0 Right Side Key - No Signal Contacts
- R1 Right Side Key - 10 Signal Contacts
- R2 Right Side Key - 20 Signal Contacts
- R3 Right Side Key - 30 Signal Contacts
- R4 Right Side Key - 40 Signal Contacts
- R5 Right Side Key - 50 Signal Contacts

BODY STYLE

- 600 Receptacle, Vertical SMT w/Mounting Ears
- 800 Receptacle with Ground Fingers (Preferred), Vertical SMT w/Mounting Ears

CONTACT TERMINATION

- 47 Pin, Vertical SMT, Staggered Leads - All
- 67 Pin, Vertical SMT, Staggered Leads - High Speed Single-Sided Leads - Signals
- 87 Pin, Vertical SMT, Single-Sided Leads - High Speed Staggered Leads - Signals
- B7 Pin, Vertical SMT, Single-Sided Leads - All

TERMINATION PLATING

- 5 50 micro" Gold Contact, Sn/Pb Alloy Termination
- 7 50 micro" Gold Contact, SAC305 Plated Termination

BODY PLATING (LCP INSULATORS)

- 2 Electroless Nickel Plated Aluminum Shell
- 3 Electrodeposited Cadmium Plated Aluminum Shell
- 6 Gold Plated Aluminum Shell

HARDWARE

- 000 No Hardware
- 810 Two Turning Jackscrews, Allen Head, Captivated **
- JXX Keying Jackscrew Hardware, See Options ***

NOTES:

1. All high-speed receptacles have fluoropolymer interfacial seals.
2. Staggered leads always start on the major side for the first high speed module.
3. Single-sided leads are always on the major side.

* = Left and right key is determined by looking at the PLUG interface with the LONG SIDE downward. The key is the angled side of the interface.

** = Captivated hardware is factory installed and non-removable.

*** = Refer to catalog Page 29 for keying options.

Recommended PC Board Layout, Plug

RUGGED V-SMT
TURNING HARDWARE
STAGGERED LEADS

CONNECTOR MATING FACE (PLUG)
INSULATOR A = SIGNAL CONTACTS
RIGHT SIDE KEY

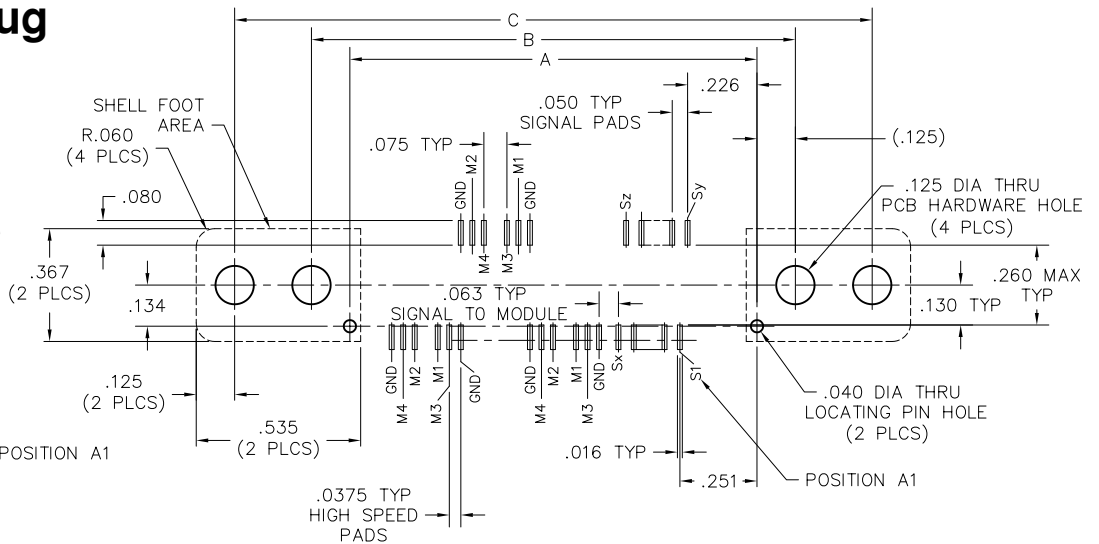
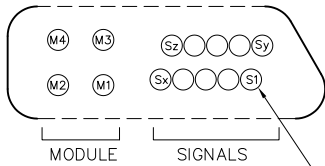

DIMENSIONS	
A	BODY LENGTH PER TABLE CALCULATION (SEE PAGE 6) MINUS 0.570
B	"A" PLUS 0.250
C	"A" PLUS 0.750

PLUG, LEFT SIDE KEY INSULATOR A = MODULE CONTACTS 3 MODULES + SIGNAL SHOWN PC BOARD LAYOUT COMPONENT SIDE

CONNECTOR MATING FACE (PLUG)
INSULATOR A = MODULE CONTACTS
LEFT SIDE KEY

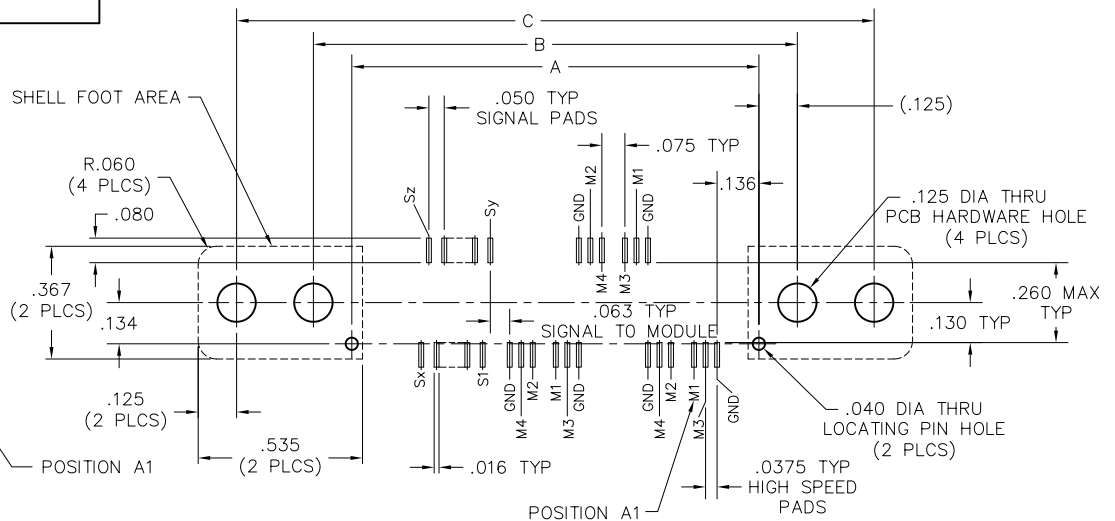
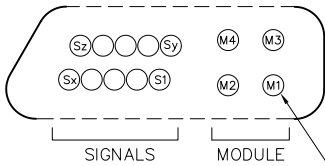

SIGNAL CONTACT NUMBERING					
	SIG10	SIG20	SIG30	SIG40	SIG50
Sx	5	10	15	20	25
Sy	6	11	16	21	26
Sz	10	20	30	40	50

NOTES:

1. For module leads exiting the MAJOR SIDE, leads M3 and M4 are .080" longer than M1 and M2.
2. For module leads exiting the MINOR SIDE, leads M1 and M2 are .080" longer than M3 and M4.
3. PCB traces or IC programming will be required to compensate for lead length variation.

Recommended PC Board Layout Receptacle

RUGGED V-SMT
TURNING HARDWARE
STAGGERED LEADS

RECEPTACLE, RIGHT SIDE KEY
INSULATOR A = SIGNAL CONTACTS
3 MODULES + SIGNAL SHOWN
PC BOARD LAYOUT
COMPONENT SIDE

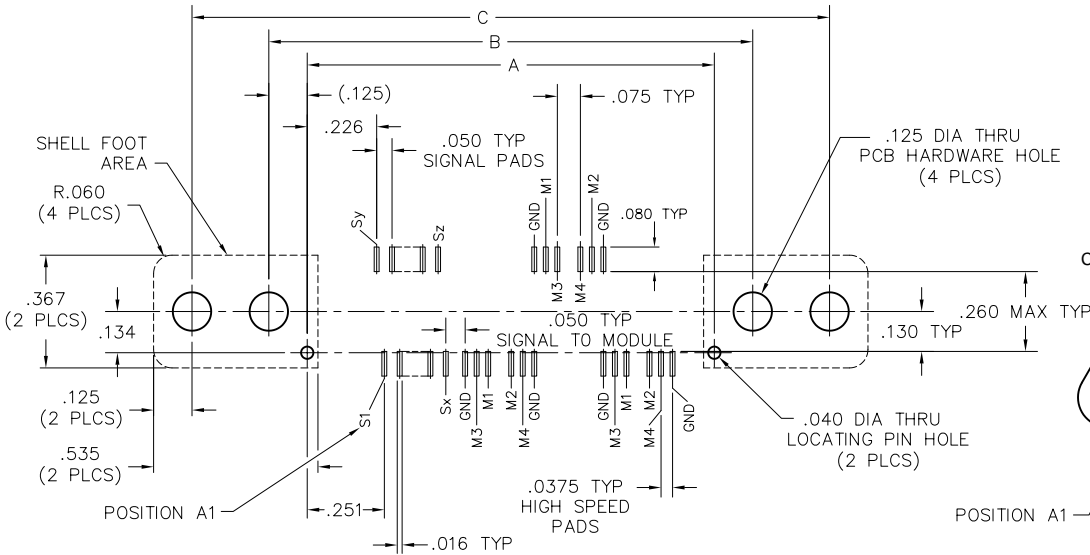

CONNECTOR MATING FACE (RECEPTACLE)
INSULATOR A = SIGNAL CONTACTS
PART NUMBER = RIGHT SIDE KEY

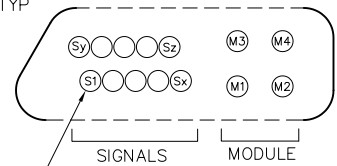

RECEPTACLE, LEFT SIDE KEY
INSULATOR A = MODULE CONTACTS
3 MODULES + SIGNAL SHOWN
PC BOARD LAYOUT
COMPONENT SIDE

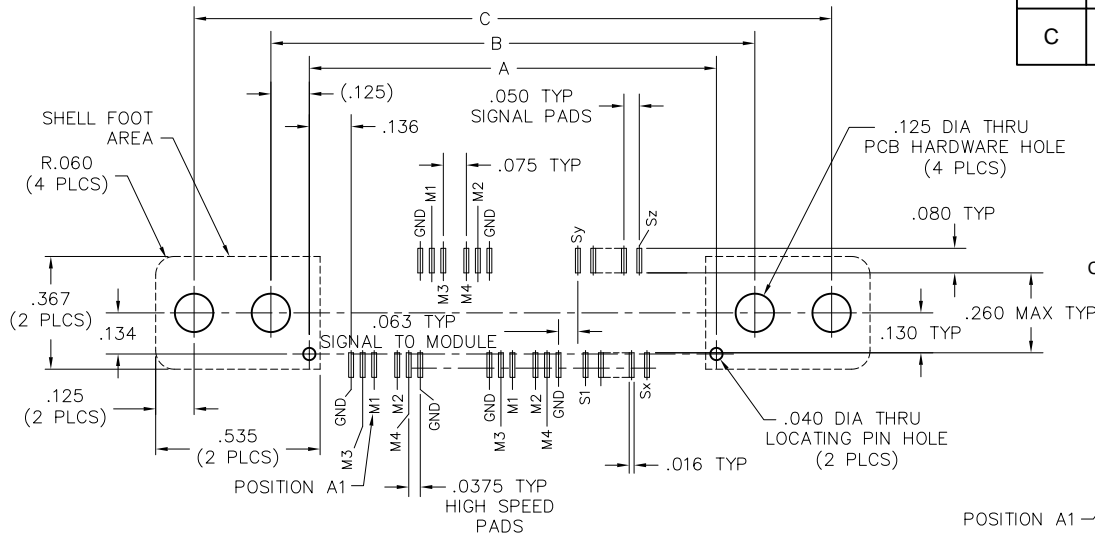

CONNECTOR MATING FACE (RECEPTACLE)
INSULATOR A = MODULE CONTACTS
PART NUMBER = LEFT SIDE KEY

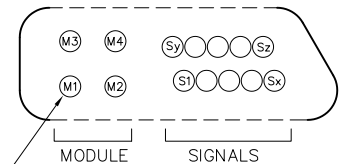

DIMENSIONS	
A	BODY LENGTH PER TABLE CALCULATION (SEE PAGE 6) MINUS 0.570
B	"A" PLUS 0.250
C	"A" PLUS 0.750

NOTES:

1. For module leads exiting the MAJOR SIDE, leads M3 and M4 are .080" longer than M1 and M2.
2. For module leads exiting the MINOR SIDE, leads M1 and M2 are .080" longer than M3 and M4.
3. PCB traces or IC programming will be required to compensate for lead length variation.
4. Receptacle interface key is swapped left-to-right from part number callout when looking at the receptacle interface.

SIGNAL CONTACT NUMBERING					
	SIG10	SIG20	SIG30	SIG40	SIG50
Sx	5	10	15	20	25
Sy	6	11	16	21	26
Sz	10	20	30	40	50

Recommended PC Board Layout, Plug

RUGGED V-SMT
TURNING HARDWARE
SINGLE-SIDED LEADS

CONNECTOR MATING FACE (PLUG)
INSULATOR A = SIGNAL CONTACTS
RIGHT SIDE KEY

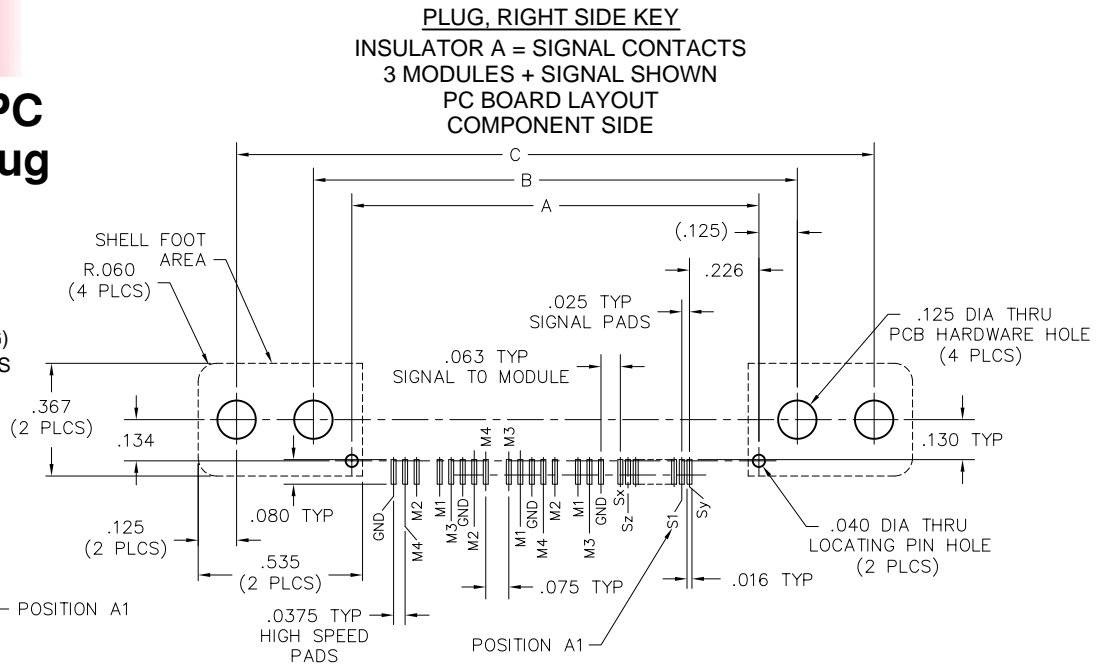
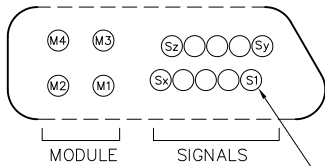

DIMENSIONS	
A	BODY LENGTH PER TABLE CALCULATION (SEE PAGE 6) MINUS 0.570
B	"A" PLUS 0.250
C	"A" PLUS 0.750

PLUG, LEFT SIDE KEY INSULATOR A = MODULE CONTACTS 3 MODULES + SIGNAL SHOWN PC BOARD LAYOUT COMPONENT SIDE

CONNECTOR MATING FACE (PLUG)
INSULATOR A = MODULE CONTACTS
LEFT SIDE KEY

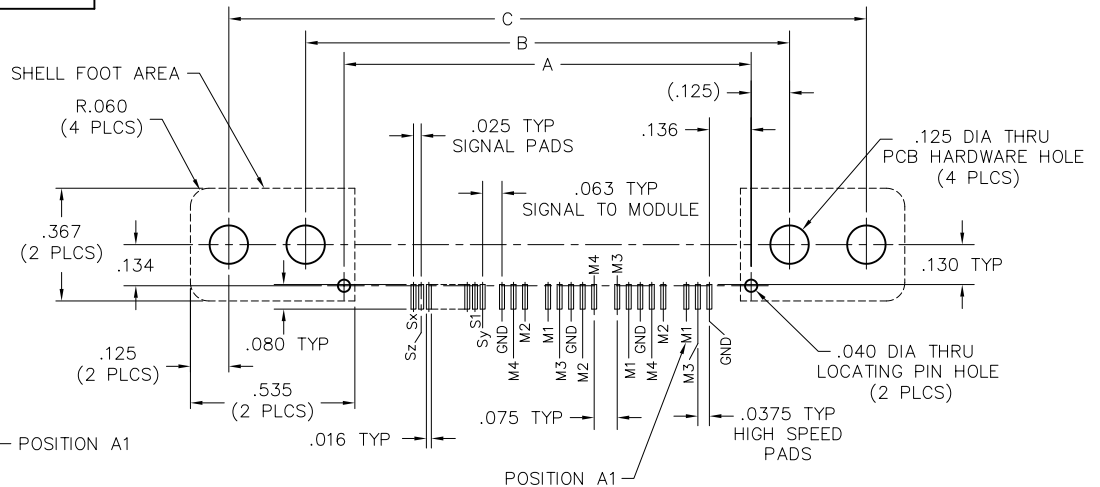
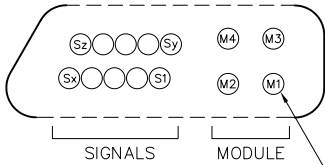

SIGNAL CONTACT NUMBERING					
	SIG10	SIG20	SIG30	SIG40	SIG50
Sx	5	10	15	20	25
Sy	6	11	16	21	26
Sz	10	20	30	40	50

NOTES:

1. For Module leads exiting the MAJOR SIDE, leads M3 and M4 are .080" longer than M1 and M2.
2. For Module leads exiting the MINOR SIDE, leads M1 and M2 are .080" longer than M3 and M4.
3. PCB traces or IC programming will be required to compensate for lead length variation.

Recommended PC Board Layout Receptacle

RUGGED V-SMT TURNING HARDWARE SINGLE-SIDED LEADS

RECEPTACLE, RIGHT SIDE KEY INSULATOR A = SIGNAL CONTACTS 3 MODULES + SIGNAL SHOWN PC BOARD LAYOUT COMPONENT SIDE

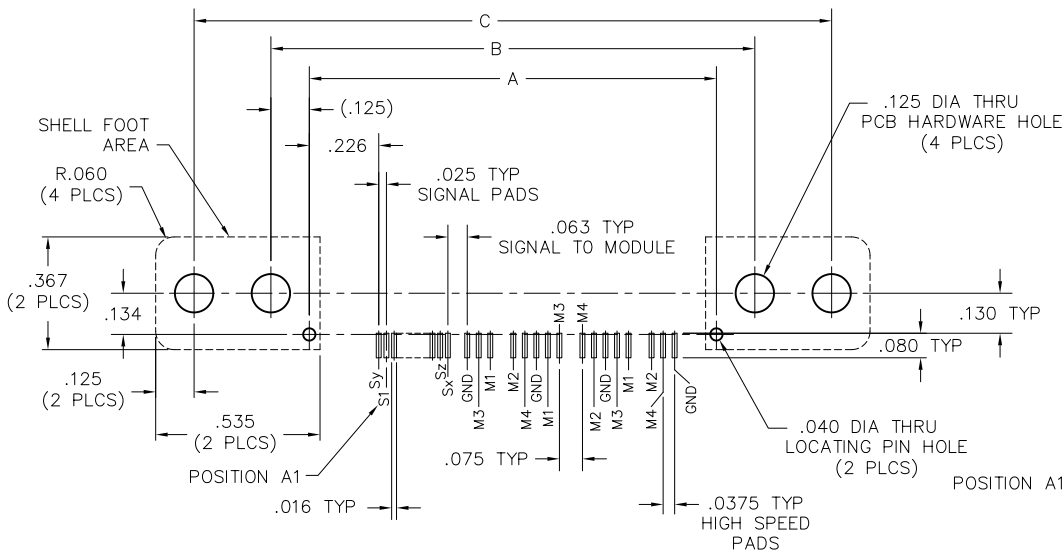

CONNECTOR MATING FACE (RECEPTACLE)
INSULATOR A = SIGNAL CONTACTS
PART NUMBER = RIGHT SIDE KEY

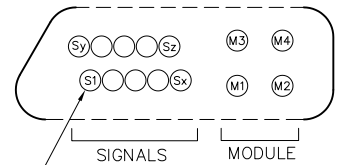

DIMENSIONS

A	BODY LENGTH PER TABLE CALCULATION (SEE PAGE 6) MINUS 0.570
B	"A" PLUS 0.250
C	"A" PLUS 0.750

RECEPTACLE, LEFT SIDE KEY INSULATOR A = MODULE CONTACTS 3 MODULES + SIGNAL SHOWN PC BOARD LAYOUT COMPONENT SIDE

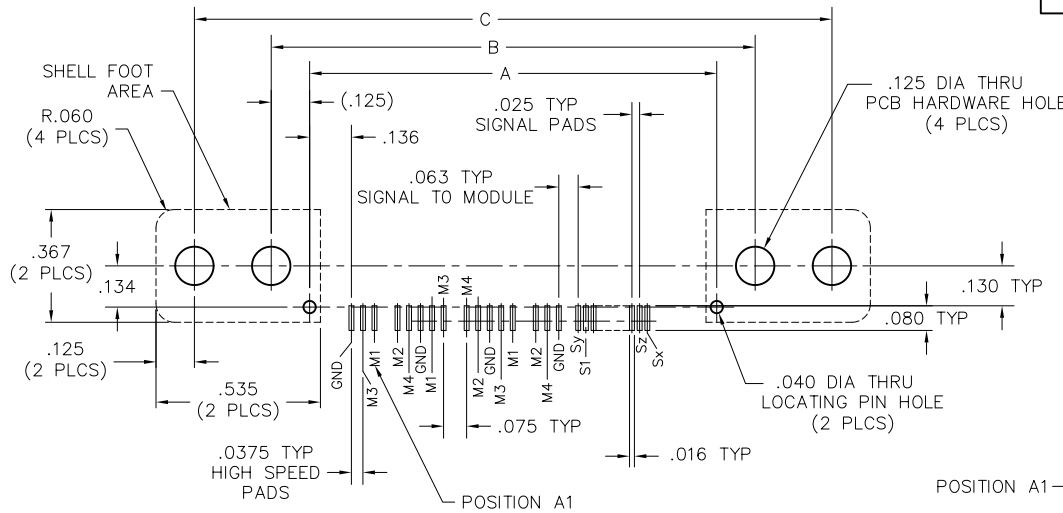

CONNECTOR MATING FACE (RECEPTACLE)
INSULATOR A = MODULE CONTACTS
PART NUMBER = LEFT SIDE KEY

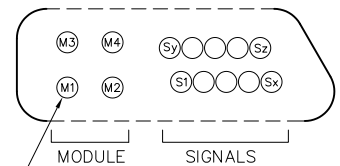

NOTES:

1. For module leads exiting the MAJOR SIDE, leads M3 and M4 are .080" longer than M1 and M2.
2. For module leads exiting the MINOR SIDE, leads M1 and M2 are .080" longer than M3 and M4.
3. PCB traces or IC programming will be required to compensate for lead length variation.
4. Receptacle interface key is swapped left-to-right from part number callout when looking at the receptacle interface.

SIGNAL CONTACT NUMBERING

	SIG10	SIG20	SIG30	SIG40	SIG50
Sx	5	10	15	20	25
Sy	6	11	16	21	26
Sz	10	20	30	40	50