

AirBorn Operating L.P.

PRODUCT TECHNICAL BULLETIN #18

Current Carrying Capacity of AirBorn's W-Series Connectors

This application note is intended to help customers determine the maximum continuous current that can be safely carried by AirBorn's W-Series connectors under a variety of conditions often encountered in typical applications. Although Mil-Dtl-55302 (the Mil Spec to which the W-Series connectors are qualified) arbitrarily rates the size 22 contacts used in the W-Series connectors at 5 amps, that rating is of little practical use because it fails to account for the effects of application related variables which can have a significant effect on the ability of the contact to carry current without overheating. Under some conditions the contacts in AirBorn's W-Series connectors are capable of carrying well over their Mil-Spec rated currents, while under other conditions, they should really be derated to lower values. The two most important application variables which affect current carrying capacity are the ambient temperature, and the number of contacts which carry current simultaneously. The electrical conductivity of the material from which the contact is made is also an extremely important design variable, and even though Mil-Dtl-55302 allows the use of several different contact materials with dramatically different electrical conductivities, it makes no distinction between them in terms of their relative ability to carry high currents. These variables, and their effects on the ability of the contact to carry current continuously, will be described below.

The ability of any connector contact to carry current is limited primarily by the maximum allowable operating temperatures of the socket contact material(s), and the plastic connector housing material. In many rugged military connectors, the maximum, safe, continuous operating temperature of the material used for the spring member in the socket contact is lower than that of the plastic housing material and thus it becomes the limiting factor. That is the case with AirBorn's W-Series connectors discussed in this technical bulletin. The housing material used in these connectors is Polyphenylene Sulfide (*PPS* - Fortron[®]) which has a UL temperature index rating of between 130°C and 220°C depending on the type of rating (electrical or mechanical) and the thickness of the wall section. These maximum continuous use temperatures are higher than those of the spring metals

(Copper Beryllium; BeCu) used for the spring contacts in these connectors, even though the metals can withstand much higher temperatures than the plastic for short periods of time.

A significant amount of heat is generated in a size 22 contact when it carries a current of more than two or three amps. This internal heat generation causes the contact to become hotter than its surroundings. This rise in the temperature of the contact above the ambient temperature will continue until it has reached an "equilibrium temperature". The equilibrium temperature is the temperature at which the rate of heat transfer from the hot contact to the surroundings is exactly equal to the rate at which heat is generated internally. When the heat output balances the heat input, the contact temperature will stabilize. At stabilization the difference between the contact temperature and the ambient temperature is referred to as the "*Temperature Rise*" of the contact. If the equilibrium temperature is within the safe operating temperature range of the socket spring material, then the contact is capable of carrying this level of current continuously, for very long periods of time (years).

The heat generated in the contact is a result of current (I) flowing through the resistance of the contact (R_c). The rate of internal heat generation in the contact (the electrical power input to the contact, P_i) is equal to the value of the current squared, multiplied by the contact resistance: ($P_i = I^2 R_c$). The rate at which the contact can transfer heat to the surroundings (the heat loss, or power output, P_o) is equal to the contact temperature (T_c) minus the temperature of the surroundings (the "ambient" temperature, T_a) multiplied by the "heat transfer coefficient" (H).

In equation form, $P_o = H(T_c - T_a)$. Note that ($T_c - T_a$) is the *Temperature Rise* as described above.

As discussed above, the contact temperature will stabilize when the power input is equal to the power output, or when:

$$(1) \quad I^2 R_c = H(T_c - T_a) \text{ which when solved for } T_c \text{ yields: } T_c = (I^2 R_c / H) + T_a$$

This equation defines how the contact temperature is affected by the variables; current, ambient temperature, contact resistance and heat transfer coefficient. The current carrying capacity of the contact can be determined by finding combinations of these variables which keep the contact temperature at, or below, the maximum safe operating temperature of the spring material (T_{s-max}).

If T_{s-max} is substituted for T_c in equation (1) above, the current that will cause the contact to operate continuously at a temperature of T_{s-max} can be calculated. This is the maximum current that the contact can carry without overheating (I_{max}).

Substituting T_{s-max} for T_c in equation (1) and solving for I_{max} :

$$(I_{max})^2 R_c = H(T_{s-max} - T_a)$$

so that: $I_{max} = (H/R_c(T_{s-max} - T_a))^{1/2}$

or, (2) $I_{max} = (K(T_{s-max} - T_a))^{1/2}$

where: $K = H/R_c$

These equations show that the maximum current that the contact can carry depends on several parameters:

1. the value of T_{s-max} ;
2. the ambient temperature;
3. the heat transfer coefficient; and
4. the contact resistance.

Since the contact resistance is also a constant, it has been combined with the heat transfer coefficient into a single constant, K. The significance of each of these variables is discussed below.

1. T_{s-max} : The value of T_{s-max} depends on the socket spring material. For AirBorn's W-Series connectors the socket contact spring material is heat treated Copper Beryllium (BeCu) alloy C17200 plated with gold over nickel. Because of its excellent “stress relaxation” properties, BeCu C17200 is capable of long term, continuous operation at temperatures as high as 100°C to 125°C depending on the accumulated total exposure time. However, long term continuous exposure (‘many years’) of BeCu alloy C17200 contacts in the mated condition (i.e. under stress) to temperatures above 125°C will result in gradual loss of contact force, and should be avoided. Thus the value of T_{s-max} used to find I_{max} using equation (2) above should be between 100°C and 125°C depending on total accumulated exposure time. For the purposes of this application note, a value of 125°C will be assumed since few applications require the connector to carry high current continuously at high ambient temperatures for many years.

2. Ambient Temperature: Mil-Dtl-55302 rates qualified connectors for continuous operation at ambient temperatures of up to 125°C. While this is acceptable for contacts which only carry low current signals (milliamps), a quick look at equation (1) reveals that this ambient temperature is too high for power contacts which must carry high current for long periods of time because the contacts will have to operate at temperatures considerably above the ambient temperature (in this case considerably above 125°C) whenever they are carrying substantial current. Short duration exposure to high ambient temperature, and the ability of the contact to handle short duration high current “pulses” are separate issues, and are not covered in this technical bulletin. All other things being equal, a connector operating in a low temperature environment is capable of carrying more current than the same connector in a high temperature environment.

3. H and R_c (K): The value of the heat transfer coefficient depends on a number of factors which influence the ease with which heat can be dissipated from the contact. The most important of these factors are; airflow, connector mounting, and the number of closely spaced contacts which carry high current at the same time.

Airflow: High velocity airflow around the connector results in a large heat transfer coefficient, while stagnant air reduces it. Operation in a vacuum (space applications) where there is not only no airflow, but no air at all, is a separate issue, and the data presented in this technical bulletin does not apply to these applications. All other things being equal, a connector in a moving air environment will be able to carry a higher current without overheating than the same connector in a still air environment, and a connector in a still air environment will be able to carry more current than a connector in a vacuum. All of the data presented at the end of this document is based on testing in a still air environment.

Mounting: Similarly, a connector mounted to a large, metal core circuit board, or other thermally conductive surface, can dissipate heat more efficiently, and will be able to carry more current than a connector suspended in mid-air, connected only to small gage wires in a cable.

Number of closely spaced contacts: The number of contacts which carry current simultaneously is important because, when the contacts are clustered together in a small area of the connector, the contacts in the center of the cluster must dissipate the heat which they generate through the hot neighboring contacts which surround them. Therefore, to the contacts in the center of a cluster, the *apparent* ambient temperature surrounding them appears to be very high, thus limiting their ability to dissipate heat. Therefore, if only one contact in a connector is required to carry significant current, this single contact will be able to carry more current without overheating than if several closely spaced contacts must be used to carry large currents simultaneously. The diagram to the right shows several examples of typical layouts of powered and unpowered contacts used during the testing described in this technical bulletin.

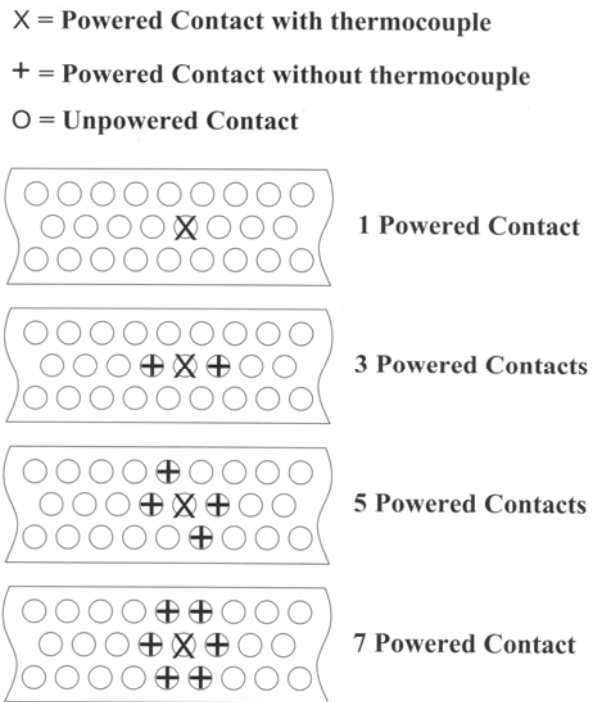

Depending on the factors just discussed, the heat transfer coefficient can take on a wide variety of values. For the purposes of generating the current rating curves presented later in this Technical Bulletin, AirBorn chose to use heat transfer coefficients based on assumptions of worst case airflow (still air), and worst case mounting condition (hanging in air, connected only by wires). This results in current ratings which are somewhat conservative for most applications. The method used to determine the value of the heat transfer coefficient is described below.

For a given set of mounting, airflow and simultaneously powered contact conditions, the heat transfer coefficient is quite easy to measure experimentally. This is done by running a constant current through the contact(s), while monitoring the socket contact spring temperature using a very fine gage thermocouple. The contact temperature is measured after allowing sufficient time for it to reach equilibrium. The ambient air temperature and the contact resistance are also measured. These values can then be used in Equation (1) to solve for the value of

H. The test is repeated several times with different numbers of current carrying contacts clustered together and a new H (or K) value is calculated for each combination.

Graphs of ambient temperature vs. maximum current for the W-Series connectors are shown on page 8 at the end of this document. Also shown on page 9 are data for the RSW Series. The RSW series connector is a hybrid of the W-Series connectors (size 22 contacts on a 0.100" pitch), and the R-Series (size 24 contacts on a 0.075" pitch),. The RSW connectors have R-Series size 24 contacts on a 0.100" pitch. These graphs show quite clearly that the maximum current carrying capacity decreases as either the ambient temperature, or the number of contacts powered simultaneously increases.

These graphs can be interpreted as follows. Suppose that you need to determine the maximum current that can be carried continuously for long periods of time by each of 3 closely spaced contacts in an AirBorn RSW-Series connector at an ambient temperature of 70°C. Using the graph for the RSW Series connectors on page 9, first locate the curve which corresponds to 3 powered contacts (magenta). Next, find the horizontal line corresponding to 70°C on the 'Ambient Temperature' axis (the 'Y' axis). Now find the intersection of the '3-contacts' curve and the horizontal 70°C line. Last, locate the point on the 'X' axis (the 'Maximum Current' axis) which is immediately below the point of intersection. This current is about 5.8 amps.

By using the graphs on the following pages in this way, it's easy to make reasonable estimates of the maximum current that can be carried safely under a variety of application conditions. Under most circumstances the estimates made based on this data will be somewhat conservative, but it is better to err on the side of conservative current carrying estimates than it is to overestimate the amount of current that the connector can carry. A contact which is forced to carry more current than it is capable of handling can rapidly overheat, and in extreme cases it can melt or become a fire or shock hazard.

It is critical to understand that the relationship between contact temperature and current is not linear. For example, if the equilibrium temperature of a hypothetical contact carrying a current of 5 A is 125°C, and the ambient temperature is 25°C (i.e. the *temperature rise* is 100°C), then doubling the current to 10 A will cause the contact to operate at 425°C, not 225°C (a temperature rise of 400°C, not 200°C), because the temperature rise is not proportional to the current, it is

proportional to the *square* of the current. This also works in reverse. Because of this square relationship, common “derating” practices often used in designing Mil/Aero electronics are often much more conservative than the designer may realize. It is common in many applications to derate the manufacturer’s current rating by a factor of 2. However, because of the square relationship, derating from 5 amps to 2.5 amps (in the present example) would actually result in reducing the temperature rise from 100°C to 25°C, and thus the operating temperature in this hypothetical case would drop from 125°C to 50°C. While this is certainly a conservative approach, in many applications it may be overly conservative and lead to overdesign of the product.

For further assistance, please contact AirBorn customer service at (972) 931-3200.

Current Carrying Capacity of AirBorn W-Series Connectors

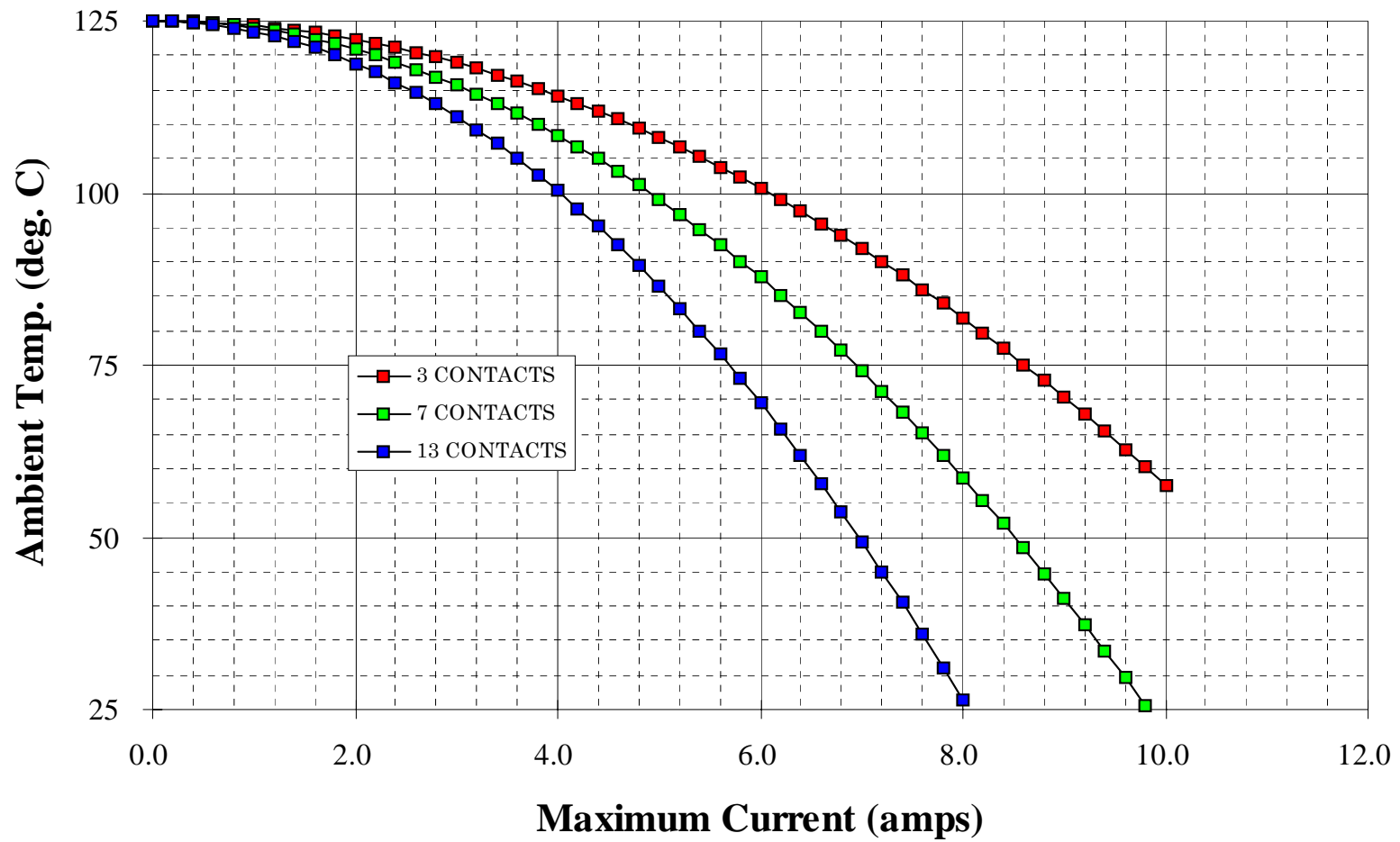

Current Carrying Capacity of AirBorn RSW Series Connectors

