



PTB49

Soldering stackable connectors

Stackable type connectors are ones in which the termination end of the contacts are intended to be used as mating pins. Since the mating pin must remain gold plated in order to have a gold-to-gold interface with the female socket, standard means of attaching the connectors to the PWB, such as wave soldering, cannot be used. Typically the method used is either hand soldering or by using solder preforms. Solder preforms are the recommended choice as they are very consistent in volume and are available in many alloys and flux content. The steps necessary to use solder preforms are very simple.

1. Mount the connector to the board.
2. Load a solder preform on each contact, making sure it seats on the PWB. (Typically tweezers are used for this operation).
3. Heat the preform with a soldering iron or reflow using an IR oven, a conveyor oven or a vapor phase process.
4. Clean the PWB with standard cleaning procedures.
5. To insure proper functioning of the contact system, there must be a minimum of .140" gold plated pin above the solder fillet.

There are many suppliers of solder preforms and they can readily be found using a search for solder preforms on the internet. They are found in various sizes and/or can be custom made. A typical size for R-series product is .032 ID x .055 OD x .020 thick.

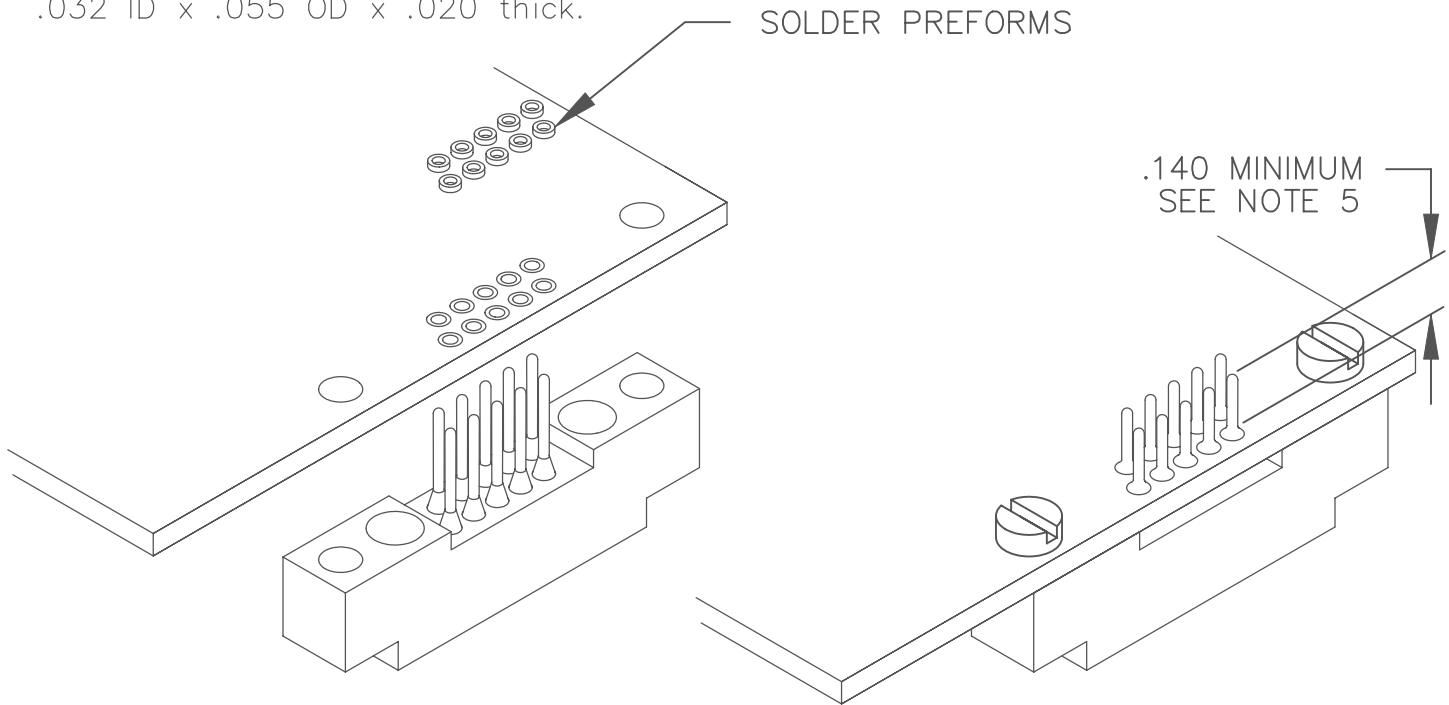

RELATED PROCEDURES	NOTICE: ALL INFORMATION DISCLOSED BY THIS DOCUMENT IS CONSIDERED CONFIDENTIAL AND PROPRIETARY BY AIRBORN INC. ALL DESIGN, USE, MANUFACTURE, REPRODUCTION, AND SALES RIGHTS ARE RESERVED BY AIRBORN INCORPORATED.				DR.	DLH	061406	AirBorn, Inc. ADDISON, TEXAS TITLE PRODUCT TECHNICAL BULLETIN SOLDERING STACKABLE CONNECTORS	CAGE CODE	10400	
				CK.	DLH	061406					
				ENGR.	DLH	061406					
				MKT	DWK	061406					
	~	INITIAL RELEASE	DLH	061406	QA	N/A	061406	SIZE	DWG.NO. PTB49	REV. SHEET	1 OF 1
SYM	REVISION	BY	APPR.	DATE	SCALE	N/A	APPR.	DATE			2

DWG. PTB49